

CAUTION: Read all instructions carefully before installation.
Save this Installation Manual for future reference.

DS-4C

RAIN/SNOW SENSOR CONTROLLER

INSTALLATION MANUAL

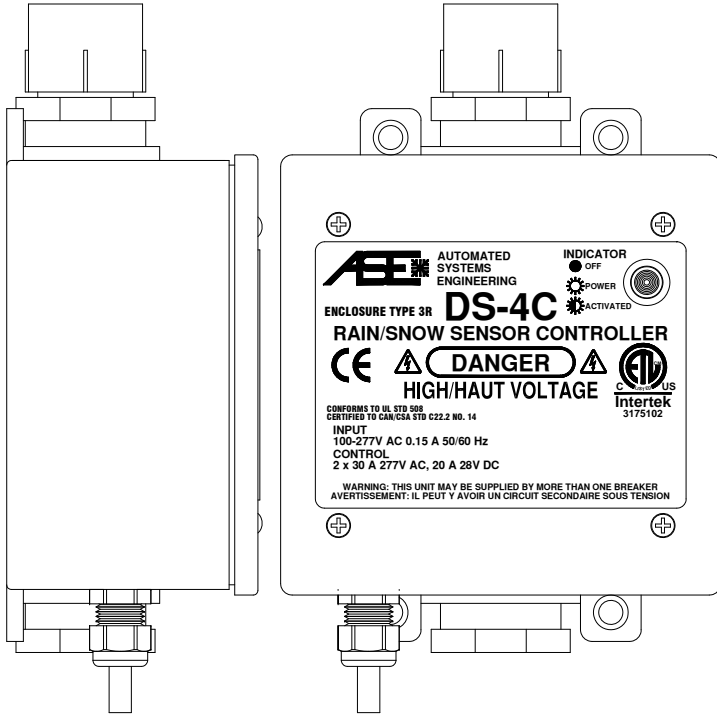

Manufactured By



**AUTOMATED
SYSTEMS
ENGINEERING**

2833 N El Paso Street Ste 100 Colorado Springs, Colorado 80907

General Safety Instructions

1. THIS UNIT SHOULD BE INSTALLED, OPENED, AND REPAIRED BY QUALIFIED PERSONNEL ONLY!

CETTE UNITÉ DEVRAIT ÊTRE INSTALLÉE, OUVERTE, ET RÉPARÉE PAR LE PERSONNEL QUALIFIÉ SEULEMENT!

2. To avoid shock hazard do not open the front cover with power connected to the DS-4C or any controlled equipment.

Pour éviter la décharge électrique déconnectez toute la puissance avant d'ouvrir la couverture du DS-4C.

Selecting a Mounting Location for the DS-4C

The interleaved grid on the top of the DS-4C is the precipitation or "moisture" sensor. The brass cylinder protruding from the bottom of the enclosure is the temperature sensor. For reliable rain and snow detection the unit must be mounted in a location that exposes the moisture sensor to a clear view of the sky. The unit should not be mounted directly under eaves or overhangs. It should not be mounted so close to the ground that it may become buried in snow. For proper temperature detection the DS-4C must be mounted outdoors, away from sources of heat. Operating temperature range is -40°C to $+85^{\circ}\text{C}$. Note that, when powered, the DS-4C moisture grid will always remain hot. This is normal. This allows the sensor to continuously melt snow and evaporate both rain and snow from the grid. The DS-4C can be mounted by screwing the base conduit hub onto an appropriate size free-standing conduit or by using the mounting holes in each corner of the enclosure.

DO NOT DRILL HOLES THROUGH THE ENCLOSURE FOR MOUNTING!

Ne Font Pas Les Trous De Foret Par La Boîte Pour Le Support!

This can allow water into the enclosure causing a potential shock hazard. It is recommended that a weatherproof junction box be mounted below the DS-4C for termination of the power and load pigtails to the equipment/building wiring.

Use Care When Replacing the Front Cover. Do Not Pinch the Gasket or Overtighten the Screws.

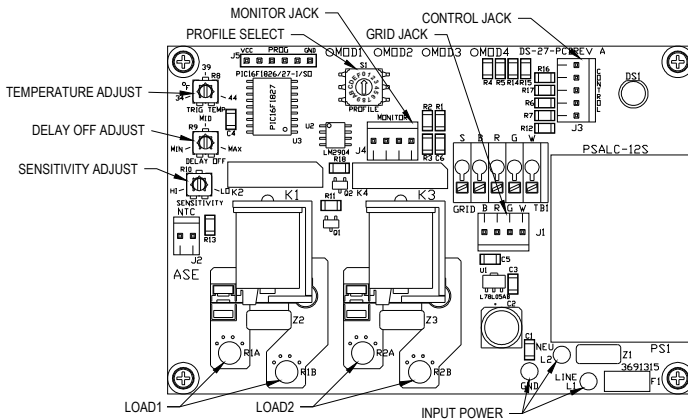

ALWAYS FOLLOW LOCAL AND NATIONAL ELECTRICAL CODES
Toujours Suivre Les Codes Électriques Locaux Et Nationaux

Power & Activation Indicator

A green lamp shines through a lens on the cover of the DS-4C to indicate operational status. If this lamp is **OFF** the DS-4C is not receiving power. If this lamp is steady **ON** the DS-4C is powered but not triggered. If this lamp blinks once Relay 1 is closed. If it blinks twice Relay 2 is closed. If it blinks three times both Relay 1 and Relay 2 are closed. Note that, even though snow or rain may have stopped, the DS-4C indicator will continue to flash during the Delay-Off drying cycle.

Setting the Configuration Switches and Adjustments

The following paragraphs and table outline the operating modes for the DS-4C and explain the functions of the adjustments. Trigger temp (TT) is adjustable from 34°F-44°F (1°C-6°C) using the TRIG TEMP control. When ambient air temperature (AT) is below this setting precipitation is assumed to be snow. When above this setting, precipitation is assumed to be rain.

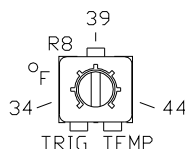

The DEL configuration switch activates the Delay-Off drying cycle timer on the DS-4C. The timer allows the DS-4C to continue to operate and dry the heated surface through evaporation

once precipitation has stopped. The drying cycle reduces the chance of moisture left behind refreezing into ice. This timer is restarted by each sensor trigger. Therefore, the DS-4C will continue to operate as long as it is triggered, then for the Delay-Off period once the trigger clears. The range of the Delay-Off adjustment is defined in the Profile Table. The adjustment will have no function if Delay-Off time is shown in the profile as a fixed value.

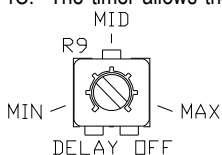

The DS-4C precipitation sensor is very sensitive and can detect a single snow flake or rain drop. However, if the DS-4C is mounted in an area susceptible to high winds, overhanging trees, or blowing ground snow, nuisance triggering may occur. While proper placement is the best remedy, the SENSITIVITY control can also be used to reduce nuisance triggering. An internal timer checks the precipitation sensor for moisture and compares cleared time with triggered time. The highest sensitivity setting (toward MORE) triggers on first detection. As the control is adjusted clockwise precipitation must be detected for a longer period to be considered valid.

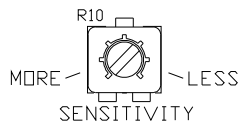

The lowest sensitivity setting (toward LESS) requires 120 seconds of detection before the unit triggers. If a trace amount of snow blows onto the grid from a drift or overhang it will likely be melted and evaporated in less than a minute. Similarly, a very light snowfall may also clear quickly from the grid. If these conditions should be ignored by the sensor the SENSITIVITY control can be adjusted as required. However, to prevent non-triggering during a true event, it is recommended that **the user start at highest sensitivity (MORE), then adjust while monitoring operation over time.**

Fine Adjustment for Efficient Operation

The DS-4C is shipped with the TRIG TEMP and DELAY OFF adjustments in the center position, representing 39°F (3.9°C) and mid point of Delay-Off time respectively. It is also set for highest SENSITIVITY. Depending on local conditions the user may find that fine adjustment of the controls may provide more satisfactory operation. If the sensor does not trigger during very wet snows the trigger temperature may need to be adjusted higher. Constant triggers from snow falling from trees or overhangs may be reduced by adjusting SENSITIVITY. The Delay-Off time can also be adjusted to provide clean melt-off without excessive running time. Fine adjustment can both save operating expense and provide more reliable operation. However, to keep reliability high, always make adjustments in small increments.

Profile Selection

The DS-4C was designed to be as adaptable as possible to different operating requirements. The mode of operation, called the "profile", can be selected by setting the Profile Select switch. A profile is selected by aligning the arrow on the screwdriver slot of the switch with the appropriate number or letter. The following table lists the operating characteristics of each profile. **A CHANGE IN PROFILE WILL NOT TAKE EFFECT UNTIL THE DS-4C HAS HAD POWER REMOVED, THEN REAPPLIED.** All profiles observe the 34°F to 44°F adjustable trigger temperature. Deice functions occur when temperatures are below or equal to the trigger temperature and precipitation is detected. Rain functions occur when temperatures are above the trigger temperature and precipitation is detected. Profiles noted as "Low Temp Cutoff" do not initially trigger below 15°F but will retrigger if triggered above 15°F but temperature then drops below 15°F. "Delay-Off" is the minimum time the relay will remain closed after a detection. All delays are restarted by a detection during the Delay-Off period. Functions for the external control leads for each profile are listed.

Profile 0		Low Temp/Precipitation Sensor with Low Temp Cutoff		
Profile 1		Low Temp/Precipitation Sensor without Low Temp Cutoff		
Relay	Function	Delay-Off	Black	Low Temp Manual On
Relay 1	Low Temp	20 sec	Green	Low Temp Standby/Reset
Relay 2	Precip	20 sec	Red	Precip Manual On
			Orange	Precip Standby/Reset

Profile 2		Deice/Rain Diversion Sensor with Low Temp Cutoff		
Profile 3		Deice/Rain Diversion Sensor without Low Temp Cutoff		
Relay	Function	Delay-Off	Black	Deice Manual On
Relay 1	Deice	20 sec	Green	Deice Standby/Reset
Relay 2	Rain	20 sec	Red	Rain Manual On
			Orange	Rain Standby/Reset

Profile 4		Deice/Rain Diversion Controller with Low Temp Cutoff		
Profile 5		Deice/Rain Diversion Controller without Low Temp Cutoff		
Relay	Function	Delay-Off	Black	Deice Manual On
Relay 1	Deice	30-93 min	Green	Deice Standby/Reset
Relay 2	Rain	2 min	Red	Rain Manual On
			Orange	Rain Standby/Reset

Profile 6		Dual Deice Controller with Low Temp Cutoff		
Profile 7		Dual Deice Controller without Low Temp Cutoff		
Relay	Function	Delay-Off	Black	Deice Manual On
Relay 1 & 2	Deice	30-93 min	Green	Deice Standby/Reset
			Red	Not Used
			Orange	Not Used

Profile 8		DS-9B Replacement with Delay, without Rain Diversion, and 2 Minute Cooldown		
Relay	Function	Delay-Off	Black	Deice Manual On
Relay 1	Deice	30-93 min	Green	Deice Standby/Reset
Relay 2	Deice	Relay 1 + 2 min	Red	Not Used
			Orange	Not Used

Profile 9 DS-9B Replacement with Delay On, Rain Diversion and 2 Minute Cooldown				
Relay	Function	Delay-Off		
Relay 1	Deice	30-93 min	Black	Deice Manual On
Relay 2	Deice	Relay 1 + 2 min	Green	Deice Standby/Reset
Relay 2	Rain	2 min	Red	Rain Manual On
			Orange	Rain Standby/Reset

Profile A Dual Deice Controller with 4°F Supercold Trigger				
Relay	Function	Delay-Off		
Relay 1 & 2	Deice/Supercold	30-93 min	Black	Deice Manual On
			Green	Deice Standby/Reset
			Red	Not Used
			Orange	Not Used

Profile B DS-9B/DDC-400 Sensor Replacement				
Relay	Function	Delay-Off		
Relay 1	Deice	20 sec	Black	Deice Manual On
Relay 2	Deice	Relay 1 + 2 min	Green	Deice Standby/Reset
Relay 2	Rain	2 min	Red	Rain Manual On
			Orange	Rain Standby/Reset

Profile C Deice/Rain Div Controller with Delay On, Rain Diversion and 30 Minute Cooldown				
Relay	Function	Delay-Off		
Relay 1	Deice	30-93 min	Black	Deice Manual On
Relay 2	Deice	Relay 1 + 30 min	Green	Deice Standby/Reset
Relay 2	Rain	30 min	Red	Rain Manual On
			Orange	Rain Standby/Reset

Profile D Not Assigned				
Relay	Function	Delay-Off		
Relay 1			Black	
Relay 2			Green	
			Red	
			Orange	

Profile E Not Assigned				
Relay	Function	Delay-Off		
Relay 1			Black	
Relay 2			Green	
			Red	
			Orange	

Profile F Not Assigned				
Relay	Function	Delay-Off		
Relay 1			Black	
Relay 2			Green	
			Red	
			Orange	

POWER MUST BE CYCLED AFTER CHANGING THE PROFILE SELECT SWITCH
L'alimentation Doit Être Redémarrée Après Avoir Changé Le Profil Select Switch

External Control/Monitor Operation

External Control		
Pin	CS-3	Function
1	Green	See Profile Table
2	Black	See Profile Table
3	Orange	See Profile Table
4	Red	See Profile Table
5	White	GND/Common

The DS-4C provides external control and monitor capability. Order the optional CS-3 "Control Cable" and CS-4 "Monitor Cable" to access these points. External Control allows the user to externally activate (Manual On) or disable and clear the delay (Standby/Reset) for the DS-4C relays. Connecting the White lead to a control lead will activate the function listed in the Profile Table. This can be achieved using a switch or dry contact. A "Standby/Reset" function will always override a companion "Manual On" function.

External Monitor		
Pin	CS-4	Function
1	Black	Relay 1 Monitor
2	Red	Relay 1 Monitor
3	Green	Relay 2 Monitor
4	White	Relay 2 Monitor

The external monitor points provide low power dry contact closures that mimic the operation of the load relays. These relays, rated at 24 VAC/VDC @ 400 mA, 10W maximum, will close with their respective load relays and can be used to externally monitor activation of the sensor.

Typical Load Wiring

The main relays are dry contacts and do not supply power directly to your load

The Yellow load leads and Red load leads connect to main relays 1 & 2 respectively. Both relays in the DS-4C activate according to the selected profile. These relays act as normally open switches and are fully isolated from each other. Each relay is intended to switch a separate circuit. Switching capacity of the DS-4C is 30A per circuit, 2 separate circuits. While not as convenient as directly supplying power for the load, dry contacts allow you to operate the DS-4C from one voltage while controlling loads of a different voltage without adding an external relay or contactor. For example, the DS-4C can be powered from 120VAC but can directly control a 240VAC heater and a 120VAC feed blower or two separate 277VAC heat cables. The following diagrams show some possible wiring schemes for connecting the DS-4C to your load. Your load may be a direct connection to heat cable, a heater, a contactor coil, or a control voltage. **For clarity the green safety GROUND leads are not shown.**

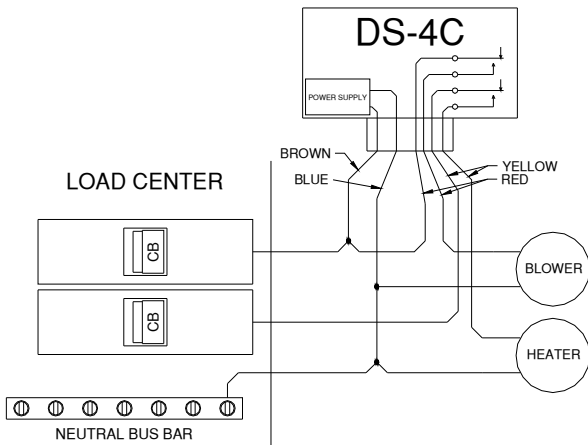

120VAC In, 120VAC Deice Heater/Rain Blower for VSAT or Similar

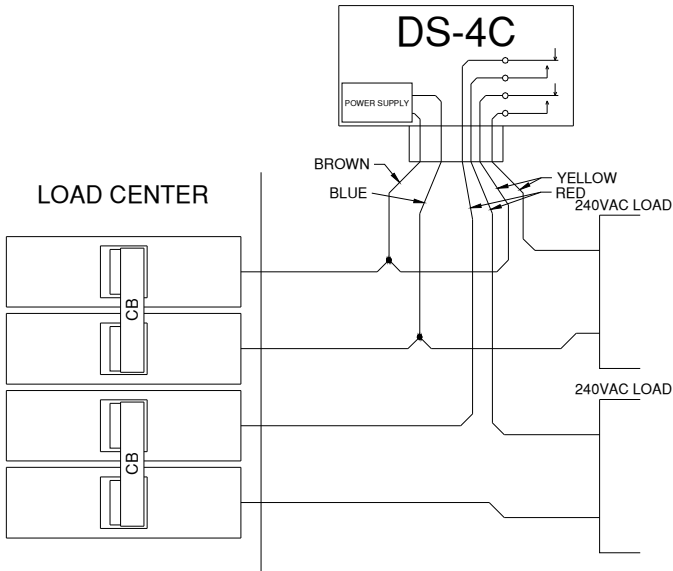

240VAC In, Dual 240VAC Load, Heat Panels or Similar

DO NOT ATTEMPT TO INCREASE SWITCHING CAPACITY BY WIRING THE RELAYS IN PARALLEL

Ne Pas Tenter D'Augmenter La Capacité De Commutation Par Le Câblage Des Relais En Parallèle

DO NOT USE THE DS-4C ENCLOSURE AS A JUNCTION BOX

Ne Pas Employer Une DS-4C As Une Boîte De Jonction

Moisture Grid Maintenance & Replacement

It is recommended that the DS-4C be powered down and the grid wiped clean with clear water at least once every 4 months. Heavy deposits may be removed using a non-metallic scouring pad (Scotch-Brite™ or equivalent.) However, after a number of years, the corrosive elements left behind when water is evaporated out of the moisture grid will eventually damage the grid rings. The moisture grid can be easily replaced by ordering and installing an MG-5 "Moisture Grid Assembly" and following the procedure below:

THIS PROCEDURE SHOULD ONLY BE PERFORMED BY QUALIFIED PERSONNEL!

CE PROCÉDÉ DEVRAIT SEULEMENT ÊTRE EXÉCUTÉ PAR LE PERSONNEL QUALIFIÉ!

Open all power and load breakers connected to the DS-4C. Open the front cover and remove the cable connector from the Grid Jack. Unscrew and remove the old moisture grid. Pass the new moisture grid connector through the top hole and screw the assembly into the reducing bushing. Tighten the grid hand tight plus ¼ turn. Connect the new cable to the Grid Jack. Confirm that the four connector pins are properly aligned with the jack. Close the front cover, confirming that the front cover gasket is properly sealed. Reapply power.

LIMITED WARRANTY

The DS-4C is warranted against defects in workmanship and materials for two years from date of sale. This warranty does not apply to damage resulting from accident, misuse, or alteration nor where connected voltage is more than 5% above the configured operating voltage, nor to equipment improperly installed or wired or maintained in violation of this Owner's Manual. No other written or oral warranty applies. No employee, agent, dealer or other person is authorized to give any warranties on behalf of ASE.

Units returned for warranty repair cannot be modified from shipped condition and leads must protrude a minimum of 6 inches from the base conduit hub. Repair costs of a modified unit will be quoted as the unit must be returned to the original, unmodified condition prior to return shipping. The customer shall be responsible for all costs incurred in the removal and/or reinstallation and shipping of the product for repairs. Within the limitations of this warranty, inoperative units should be returned, freight prepaid, to ASE, and we will repair or replace, at our option, at no charge to you with return freight paid by ASE to destinations within the U.S. and Canada. It is agreed that such repair or replacement is the exclusive remedy available from ASE and that ASE IS NOT RESPONSIBLE FOR DAMAGES OF ANY KIND, INCLUDING INCIDENTAL AND CONSEQUENTIAL DAMAGE. Some states do not allow the exclusion or limitation of incidental or consequential damages so the above exclusion may not apply to you. The warranty gives you specific legal rights, and you may also have other rights which vary from state to state.

Input: 100-277 VAC +/- 5%, 47-63 Hz
Control: 2 x 277 VAC @ 30A
Operating Temp: -40°C to +85°C



AUTOMATED SYSTEMS ENGINEERING, INC.
2833 N EL PASO ST STE 100
COLORADO SPRINGS, COLORADO 80907
PHONE: 719-599-7477

Visit us on the Internet at: www.goase.com

